



VRLA Rechargeable Battery

BP7-12G (BP7-12GFR)

FEATURES

- Solid gel standby battery
- No electrolyte stratification
- Maintenance free and no free acid
- Can be used in any orientation (excluding used inverted)

APPLICATION

- UPS
- Laboratory Equipment
- Power Packs
- Toy-Cars
- Fishing Lights
- Telecom



SPECIFICATIONS

Nominal Voltage	12V	
Nominal Capacity	20 Hour Rate (350mA, 10.5V)	7.00 Ah
	10 Hour Rate (665mA, 10.5V)	6.65 Ah
	5 Hour Rate (1190mA, 10.5V)	5.95 Ah
	1 Hour Rate (4200mA, 9.30V)	4.20 Ah
Approx. Weight	2585g(5.7lbs.)	
Terminals	T2 (Faston Tab 250) T1 is optional	
Max. Discharge Current	105 A (5 sec.)	
Max. Charge Current	1.8 A	
Operating Temperature Range	Charge	-20°C~50°C(-4°F~122°F)
	Discharge	-40°C~60°C(-40°F~140°F)
	Storage	-40°C~60°C(-40°F~140°F)
Self Discharge	< 3% per month (25°C)	
Internal Resistance	≤27mΩ (Fully Charged)	

CONTAINER MATERIAL

- BP7-12G:
ABS: UL 94-HB (Dark gray color)
- BP7-12GFR:
ABS: UL 94-V0 (Light gray color)

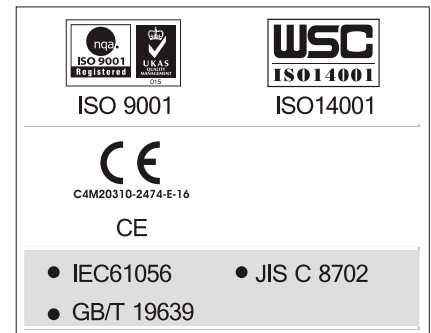

OUTER DIMENSIONS mm(inch)	Length (L)	Width (W)	Container Height (H)	Total Height (TH)
	151±1.5(5.94±0.06)	65±1.5(2.56±0.06)	93±1.5(3.66±0.06)	98±2.0(3.86±0.08)

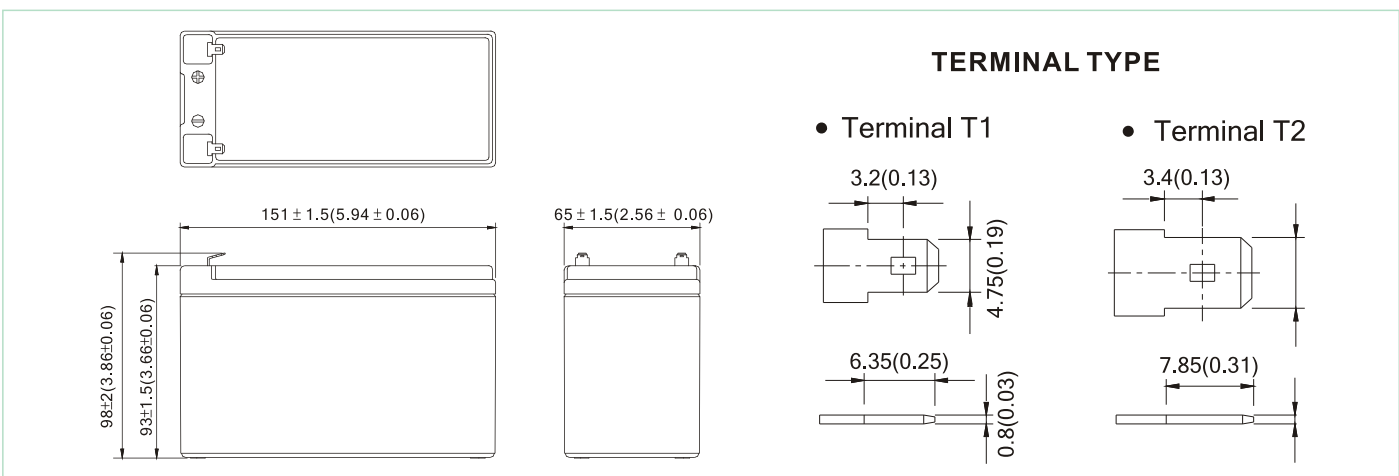

BP7-12G (BP7-12GFR) discharge characteristics (25°C/77°F)

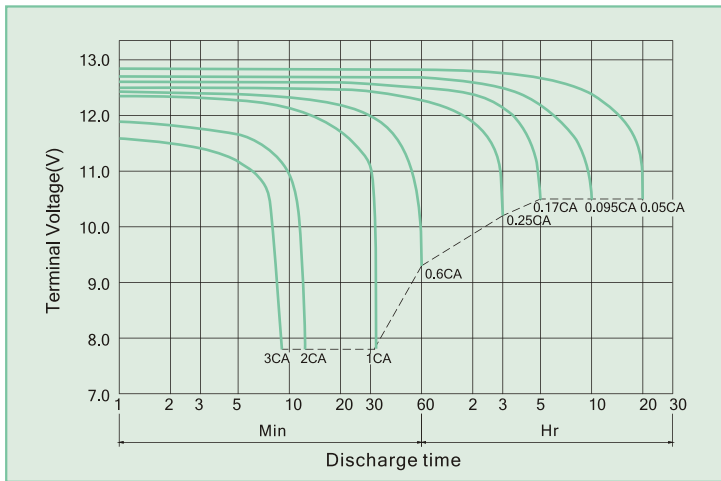

Battery Charging Characteristics

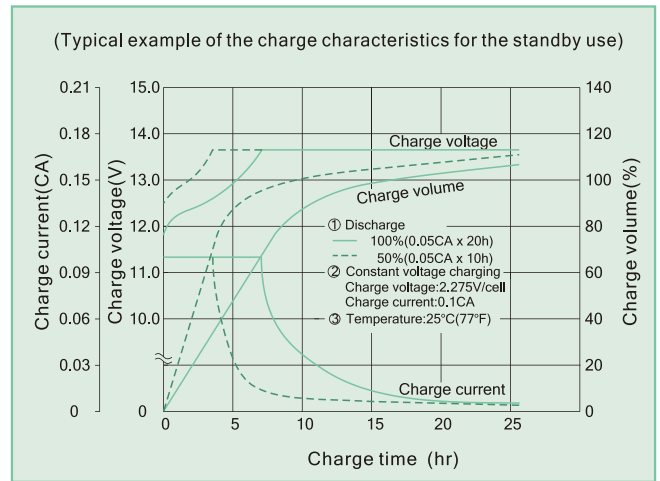

Charging Procedure

Application	Charging method	Charging Voltage at 25°C (V/cell)	Temperature compensation coefficient of charging voltage (mV/°C/cell)	Max. charging current (CA)	Charging time 0.1CA, 25°C (h)		Temp (°C)
					100% discharge	50% discharge	
For standby power Source	Constant voltage & Constant current charging (with current restriction)	2.25~2.30	-3	0.3	24	20	0~40 (32~104°F)
For cycle service		2.35~2.40	-4	0.3	18	12	

Effect Of Temperature On Long Term Float Life

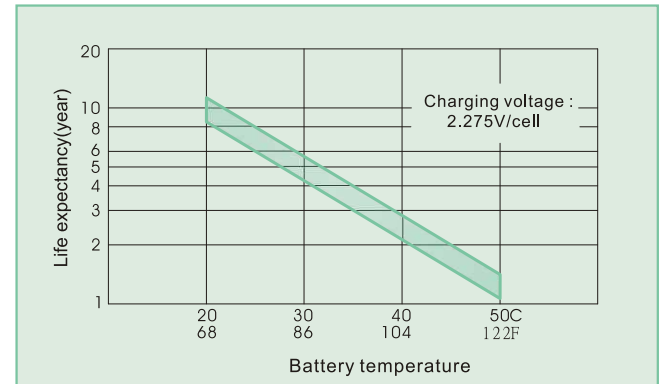

Constant power discharge characteristics at 25°C/77°F Unit: W

F.V. (V/cell) \ Discharge Time	5 Min	10 Min	15 Min	30 Min	1 Hr	3 Hr	5 Hr	10 Hr	20 Hr
1.80V	253	186	149	88.8	50.9	20.40	14.07	7.86	4.14
1.75V	293	202	156	92.2	52.5	20.81	14.28	7.98	4.20
1.70V	311	209	161	94.3	53.4	21.00	14.36	8.02	4.22
1.65V	325	214	165	95.6	54.1	21.15	14.41	8.04	4.24
1.60V	336	218	168	96.6	54.6	21.27	14.45	8.04	4.24

Constant current discharge characteristics at 25°C/77°F Unit: A

F.V. (V/cell) \ Discharge Time	5 Min	10 Min	15 Min	30 Min	1 Hr	3 Hr	5 Hr	10 Hr	20 Hr
1.80V	22.8	16.4	13.0	7.53	4.28	1.70	1.172	0.655	0.345
1.75V	26.9	17.8	13.6	7.81	4.41	1.73	1.190	0.665	0.350
1.70V	28.6	18.4	14.0	7.99	4.49	1.75	1.196	0.668	0.352
1.65V	29.8	18.8	14.3	8.11	4.54	1.76	1.201	0.670	0.353
1.60V	30.8	19.2	14.6	8.19	4.59	1.77	1.204	0.670	0.353

All data shall be changed without prior notice, BB reserves the right to explain and update the information contained hereinto.

Trial A/0 REV. Dec. 2009

USA:
 B&B BATTERY(USA) INC.
 6415 RANDOLPH ST.COMMERCE, CA,90040 U.S.A.
 TEL:1-323-278-1900.1-800-278-8599
 FAX:1-323-278-1268
 E-Mail:sales@bb-battery.com

CHINA FACTORY:
 B.B. BATTERY CO., LTD.
 CHENG DONG TRIAL AREA,HUANG GANG,
 RAOPING, GUANG DONG,CHINA,515700
 TEL:86-768-7601001-2
 FAX:86-768-7601469
 E-Mail:maggy@bb-battery.com

EUROPE:
 B&B BATTERY(EUROPE) B.V.
 LAAN VAN KRONENBRUG 8, 1183AS
 AMSTELVEEN, THE NETHERLANDS
 TEL: +852-91282711
 MOBILE: +852-91282711
 E-Mail: dliu@bb-battery.com

HONG KONG:
 NATIONAL TRADING LTD.
 TEL:852-2301-3800
 FAX:852-2739-1182
 E-Mail:bbhk@hkstar.com

JAPAN:
 B&B BATTERY(JAPAN) CO., LTD.
 1375-11 NARAHARA-MACHI,HACHIOJI,
 TOKYO 193-0803,JAPAN.
 TEL:81-426-25-6375
 FAX:81-426-25-6375
 E-Mail:miyata@bb-battery.com

TAIWAN:
 B.B. BATTERY(TAIWAN) CO., LTD.
 TEL:886-6-502-5150
 FAX:886-6-589-8087
 E-Mail:maggy@bb-battery.com