

**TSEWG TP-1: ELECTRICAL CALCULATION EXAMPLES**

**SHORT CIRCUIT CURRENT EFFECTS.**

Electrical distribution systems must be designed to withstand the maximum expected fault (short circuit) current until the short circuit current is cleared by a protective device. This is a fundamental electrical requirement. NEC Article 110.9 (2005 Edition) requires that all protective devices intended to interrupt current at fault levels must have an interrupting rating sufficient for the nominal circuit voltage and the current that is available at the line terminals of the equipment. For this reason, the maximum available short circuit current must be determined for all locations throughout the electrical system.

Figure 1 shows a simplified short circuit study for a small section of an electrical distribution system. The available fault current is shown at the service bus and at an MCC bus. As can be seen, the bulk of the short circuit current is provided by the distribution system through the transformer, with a lesser amount of current provided by each of the motors.

**Figure 1 Sample Short Circuit Results—1 MVA Transformer**

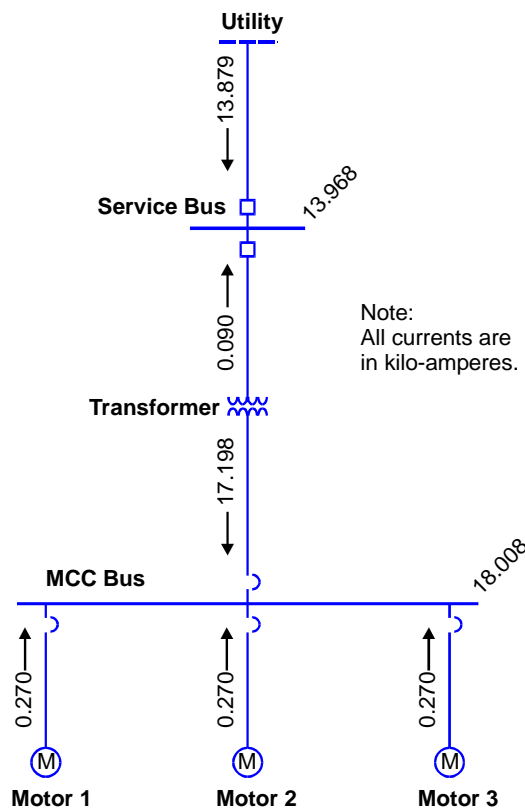

The transformer size has a significant effect on the available short circuit current. Whenever a transformer is replaced with a larger transformer, perform a short circuit study for the larger transformer to verify that all equipment is properly

sized for the increased short circuit current. Figure 2 shows an example of the increase that might be observed as a transformer size is increased from 1 MVA to 2 MVA. Comparing Figure 1 to Figure 2, the MCC bus fault current has increased from 18,000 amperes to over 30,000 amperes. Although the system breakers might have been adequately rated for use with the 1 MVA transformer, the larger 2 MVA transformer could allow a short circuit current in excess of the breakers' ratings. This example illustrates the importance of evaluating the entire electrical system whenever a change is made.

**Figure 2 Sample Short Circuit Results—2 MVA Transformer**

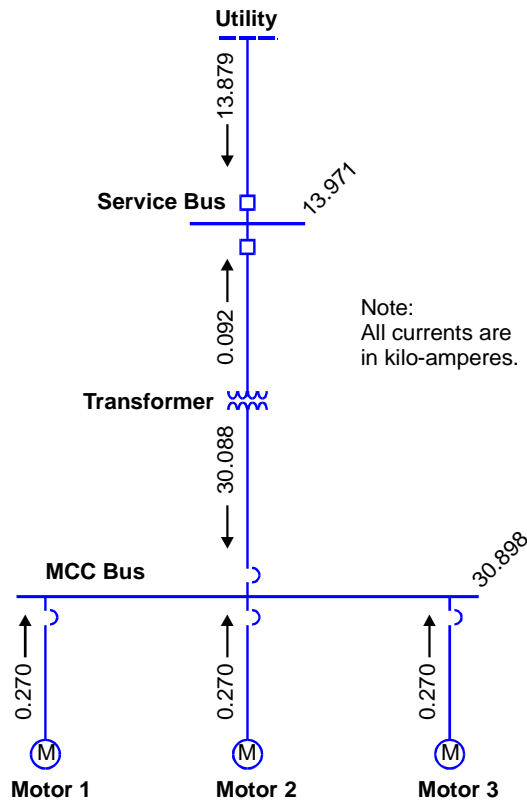

The computer program used for short circuit analysis should be capable of identifying overduty breakers (breakers in which the short-circuit current, including asymmetric current effects, exceeds the breaker interrupting rating). Figure 3 shows an example of overduty breakers. The feeder breaker to the MCC bus is 7 percent below its interrupting rating and the downstream load breakers are 33 percent over their interrupting rating.

**Figure 3 Overduty Molded Case Circuit Breakers**

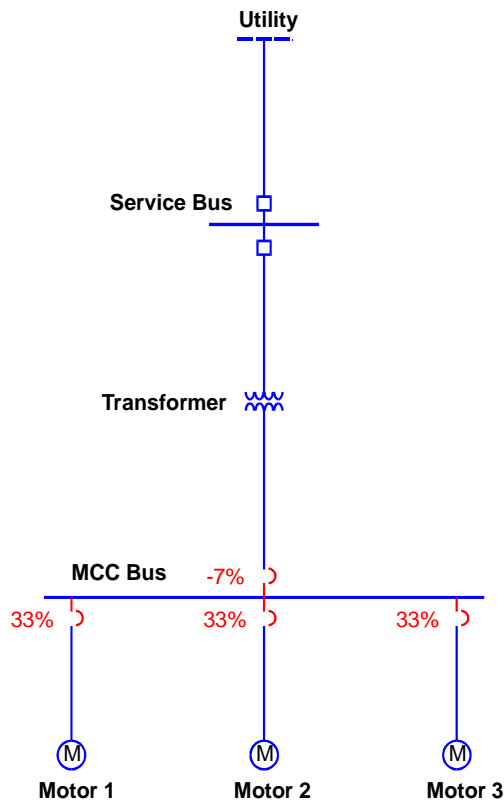

**VOLTAGE DROP.**

Calculate voltage drop by the following equation:

$$\text{Voltage Drop} = I_L \times (R \cos \theta + X \sin \theta)$$

where,

- $I_L$  = Line current in amperes
- $R$  = Resistance of line in ohms
- $X$  = Reactance of line in ohms
- $\theta$  = Phase angle between voltage and current – if phase angle is not known, assume a phase angle of 36.9 degrees corresponding to a power factor of 0.8.

The above equation is simplified, but usually provides acceptable results. In the above equation, obtain the conductor resistance and reactance values as a function of conductor size from NEC Chapter 9, Tables 8 and 9 (2005 Edition). Note that NEC conductor resistance values are based on 75 °C (167 °F) and will usually require correction to the actual expected temperature (refer to NEC

Chapter 9, Table 8, for how to convert the resistance to a different temperature). The line current is calculated based on the expected real power requirement and phase angle. The following equations show the calculation of line current:

### Single-Phase Circuits

$$I_L = \frac{P}{V \times \cos \theta}$$

where,

- $I_L$  = Line current in amperes
- $P$  = Real power, in kW
- $V$  = Voltage, RMS—in kV to match power units
- $\theta$  = Phase angle between voltage and current

### Three-Phase Circuits

$$I_L = \frac{P}{\sqrt{3} \times V_L \times \cos \theta}$$

where,

- $I_L$  = Line current in amperes
- $P$  = Total three-phase real power, in kW
- $V_L$  = Line voltage, RMS—in kV to match power units
- $\theta$  = Phase angle between voltage and current

If comparing voltage drops across different nominal voltages, reference voltage drop calculations to a 120 volt base to allow ready comparison of the voltage drops throughout the system, regardless of the actual voltage level. Use the following expression to convert a voltage drop at some nominal voltage to a 120 volt base:

$$\text{Actual Voltage Drop (120 V Base)} = \frac{\text{Actual Voltage Drop} \times 120}{\text{System Nominal Voltage}}$$

**TRANSFORMER RATED CURRENT.**

Transformer rated secondary current is calculated by dividing the rated kVA capacity by the rated secondary voltage. The following examples illustrate the rated secondary current calculation.

EXAMPLE: What is the rated secondary current of a 30-kVA single-phase transformer with a rated secondary voltage of 240 volts?

$$I_s = \frac{30 \text{ kVA} \times 1000}{240 \text{ V}} = 125 \text{ amperes}$$

EXAMPLE: What is the rated secondary current of a 100-kVA three-phase transformer with a rated secondary voltage of 480 volts?

$$I_s = \frac{100 \text{ kVA} \times 1000}{\sqrt{3} \times 480 \text{ V}} = 120 \text{ amperes}$$

The above examples do not include the effect of any losses; however, the calculations provide approximate values that are usually adequate for use.

**TRANSFORMER IMPEDANCE EFFECTS.**

For a given kVA rating, a transformer will provide a higher short circuit current as its impedance is lowered. Transformer impedance is usually expressed as a percent. A transformer rated at 10 percent impedance can supply 100%/10% = 10 times its rated secondary current into a short circuit. A transformer rated at 4 percent impedance can supply 100%/4% = 25 times its rated secondary current into a short circuit. Notice that two transformers of equal kVA capacity can have significantly different short circuit currents. This feature must be evaluated as part of the transformer sizing and selection process.

EXAMPLE: Compare the secondary short circuit current of a 500-kVA, 480 volt secondary, three-phase transformer with a 10 percent impedance to an equal capacity transformer with a 2 percent impedance.

First, calculate the rated secondary current:

$$I_{\text{rated}} = \frac{500 \text{ kVA} \times 1000}{\sqrt{3} \times 480 \text{ V}} = 600 \text{ amperes}$$

The 10 percent impedance transformer has the following expected short circuit current:

$$I_{sc-10\%} = \frac{100\%}{10\%} \times 600 \text{ amperes} = 10 \times 600 \text{ amperes} = 6,000 \text{ amperes}$$

The 2 percent impedance transformer has the following expected short circuit current:

$$I_{sc-2\%} = \frac{100\%}{2\%} \times 600 \text{ amperes} = 50 \times 600 \text{ amperes} = 30,000 \text{ amperes}$$

Notice that the 2 percent impedance transformer has 5 times the short circuit current of the 10 percent impedance transformer. The 2 percent impedance transformer might require a complete redesign of downstream electrical equipment to withstand the higher short circuit currents.

Impedance affects transformer regulation. As the impedance increases, the voltage regulation tends to increase. Voltage regulation is defined as the voltage change from no load to full load conditions:

$$\text{Regulation (percent)} = \frac{V_{no-load} - V_{full-load}}{V_{full-load}} \times 100\%$$

**TRANSFORMER SIZING.**

The following example illustrates the sizing process for a simple transformer installation. Primary and secondary conductor sizes are also determined.

EXAMPLE: A feeder supplies three-phase power to a 480 volt transformer. The transformer steps down to 208Y/120 volts to a lighting panel with a continuous load of 30 amperes on each phase. What is the required transformer kVA capacity, and required amperage on the primary and secondary?

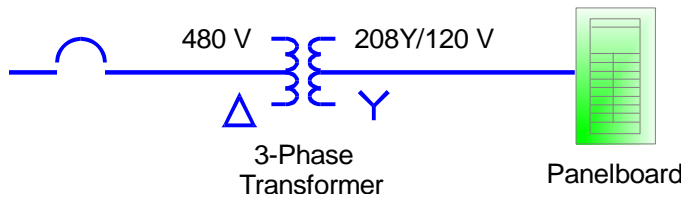

Transformer Size

The transformer required kVA capacity is given by:

$$\text{Required kVA} = \sqrt{3} \times 208 \times 30 = 10.8 \text{ kVA}$$

Transformers are provided in standard sizes. The next larger standard size above 10.8 kVA is 15 kVA. So, choose a 15 kVA transformer for this load. If additional load growth is anticipated, a larger transformer might have been

selected instead.

### Primary Ampacity

Assume that the transformer will eventually be fully loaded. The required primary amperage is:

$$I_p = \frac{15 \text{ kVA} \times 1000}{\sqrt{3} \times 480 \text{ V}} = 18 \text{ amperes}$$

Referring to NEC Table 310.16 (2005 Edition), a #12 AWG copper conductor would be selected for the primary. A #14 AWG copper conductor would not be selected even though it appears to have adequate current-carrying capacity because the footnote to NEC Table 310.16 requires that overcurrent protection be limited to 15 amperes for a #14 AWG conductor.

The NEC has an additional requirement relating to the transformer primary conductor. NEC Article 215.2(A)(1) (2005 Edition) requires that feeder conductors be sized for the noncontinuous load plus 125 percent of the continuous load. In this case, the primary conductor would be sized for 125 percent of 18 amperes, or 22.5 amperes. Referring again to NEC Table 310.16, a #12 AWG copper conductor is still acceptable for use because it has an ampacity of 25 amperes. Note that the footnote to NEC Table 310.16 requires that overcurrent protection be limited to 20 amperes for a #12 AWG conductor; however, this load limit still exceeds the 18 ampere actual load requirement and is therefore acceptable.

### Secondary Ampacity

The required secondary amperage is:

$$I_p = \frac{15 \text{ kVA} \times 1000}{\sqrt{3} \times 208 \text{ V}} = 41.6 \text{ amperes}$$

NEC Article 215.2(A)(1) requires that feeders be sized for the noncontinuous load plus 125 percent of the continuous load. In this case, the secondary conductor would be sized for 125 percent of 41.6 amperes, or 52 amperes. Referring to NEC Table 310.16, a #6 AWG copper conductor would be selected.

## **ENERGY SAVINGS WITH OVERSIZED CONDUCTORS.**

Although not a specific design requirement, every design should be evaluated for the energy savings possible by installing conductors of one size larger than required by the NEC. By increasing the wire size, reduced power losses offset the wire cost and often show a payback within a relatively short time. Also, the

increased wire size improves the system flexibility to accommodate future design changes. In summary, increasing the wire size to one size larger than required by the NEC produces the following benefits:

- Energy savings will be realized due to lower heating losses in the larger conductors.
- Less heat will be generated by the wiring system.
- The conductors will have smaller voltage drop, which will often be necessary to meet other design criteria. For example, IEEE 1100 recommends a maximum voltage drop of 1 percent for electronic installations.
- Greater flexibility will be available in the existing system to accommodate future load growth.
- The system can better accommodate the adverse effects of nonlinear loads.

In many cases, no changes to the raceway system will be necessary to accommodate a larger cable. In these cases, the payback period for energy savings is often less than 2 years. Even if a larger conduit is required, a reasonable payback period is often achievable. To ensure that energy savings can actually be obtained without other hidden costs, ensure that the larger conductor is compatible with the upstream breaker or fuse, as well as the downstream load, in terms of physical size and termination ability.

The following examples illustrate the evaluation process as well as the potential savings that can be realized.

<p>EXAMPLE: A three-phase circuit feeds a 125 horsepower (93,250 watts), 460 volt motor, operating at 75 percent load, 76.2 meters (250 feet) from the load center. Assume that the motor operates only 50 percent of the time (4,380 hours per year). The motor full load current is 156 amperes and 75 percent of this load is 117 amperes.</p> <p>A #3/0 AWG conductor satisfies the electrical requirements. As shown below, a larger #4/0 AWG conductor pays for itself within 5 years. Thereafter, the installation continues to save energy costs of almost \$50 per year compared to the smaller #3/0 AWG conductor.</p>		
<u>Input Data</u>	<u>#3/0 AWG</u>	<u>#4/0 AWG</u>
Conduit size inch)	51 mm (2 inch)	51 mm (2
Conductor resistance (30 °C)	0.0164	0.0130



Estimated power loss (3 phase)	673 W	534 W
Estimated wire cost	\$991	\$1,232
Estimated conduit cost	\$365	\$365
Incremental cost		\$241
Projected energy savings		609
kWh/year		
Cost savings at \$0.08 per kWh		\$48.72/year
Payback period		5 year

In the above example, the copper conductor resistance was obtained from NEC Chapter 9, Table 8 (2005 Edition), and corrected for use at 30 °C (rather than 75 °C as listed in the table) in accordance with the following expression provided by a footnote in the same table:

$$R_2 = R_1 \times [1 + 0.00323 \times (T - 75)]$$

where  $R_1$  is the copper conductor resistance at 75 °C.

The estimated power loss was then calculated by:

$$Power\ Loss = I^2 \times R$$

EXAMPLE: A single-phase, 15 ampere lighting load operates only 50 hours per week (2,600 hours per year) and is located 30.5 meters (100 feet) from the load center. As shown below, the larger #10 AWG conductor pays for itself in just over 1 year. Thereafter, the installation continues to save energy costs of almost \$6 per year compared to the smaller #12 AWG conductor.

<u>Input Data</u>	<u>#12 AWG</u>	<u>#10 AWG</u>
Conduit size	12.7 mm (0.5 inch)	12.7 mm (0.5 inch)
Conductor resistance (30 °C)	0.3384	0.2120
Estimated power loss (1 phase)	76 W	48 W
Estimated wire cost	\$12	\$19
Estimated conduit cost	\$42	\$42
Incremental cost		\$7
Projected energy savings		73 kWh/year
Cost savings at \$0.08 per kWh		\$5.8/year
Payback period		1.2 year

EXAMPLE: Even if a larger conduit is required, an acceptable payback can be achievable with a larger wire size. For this example, assume that a three-phase, 40 ampere lighting load operates for only 4,000 hours per

year (which is about 11 hours per day) and is located 61 meters (200 feet) from the load center. As shown below, the larger #6 AWG conductor pays for itself in 1.5 years. Thereafter, the installation continues to save energy costs of over \$75 per year compared to the smaller #8 AWG conductor.

<u>Input Data</u>	<u>#8 AWG</u>	<u>#6 AWG</u>
Conduit size (1 inch)	19.1 mm (0.75 inch)	25.4 mm
Conductor resistance (30 °C)	0.1330	0.0839
Estimated power loss (3 phase)	638 W	403 W
Estimated wire cost	\$117	\$166
Estimated conduit cost	\$128	\$192
Incremental cost		\$113
Projected energy savings kWh/year		940
Cost savings at \$0.08 per kWh \$75.2/year		
Payback period		1.5 year

As the above examples illustrate, a significant energy savings can be realized by increasing the conductor size to the next higher gauge size.

**ADJUSTABLE SPEED DRIVE ECONOMIC EVALUATION.**

If an ASD installation is considered on the basis of energy efficiency, perform an economic evaluation in accordance with the process shown in Figure 4.

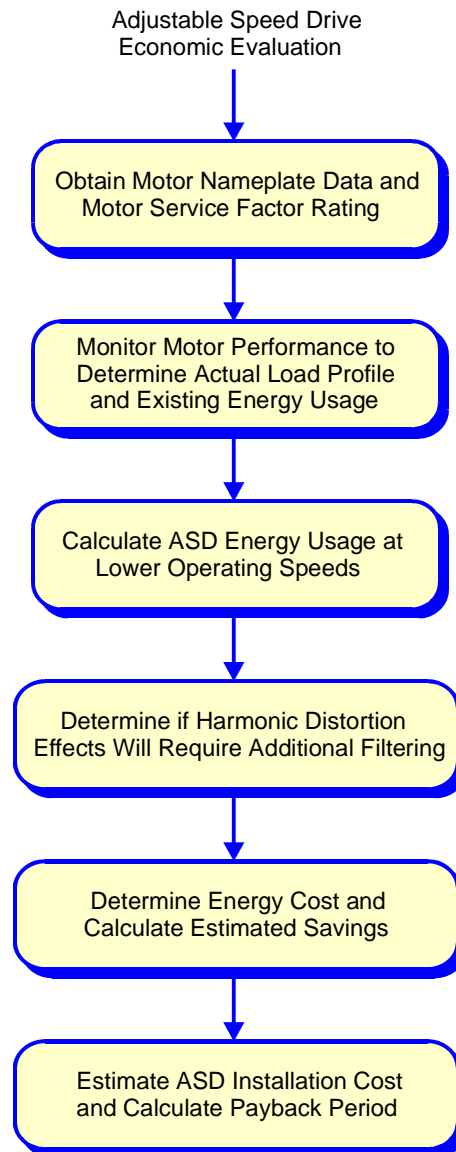
**Figure 4 Adjustable Speed Drive Economic Evaluation**

The key to an economic evaluation is to determine whether or not the motor will be fully loaded under expected operating conditions. If the motor is always loaded at or near 100 percent of rated load, then little if any savings will be realized. Fortunately, it is common to discover that the actual load current is significantly less than rated. For example, Figure 5 shows a typical case in which a 60 horsepower (44,800 watts) motor normally operates at a load of less than 24 kW. In this case, an ASD can provide substantial savings.

**Figure 5 Typical Motor Load Profile With Motor Operating at Half of Rated Load**

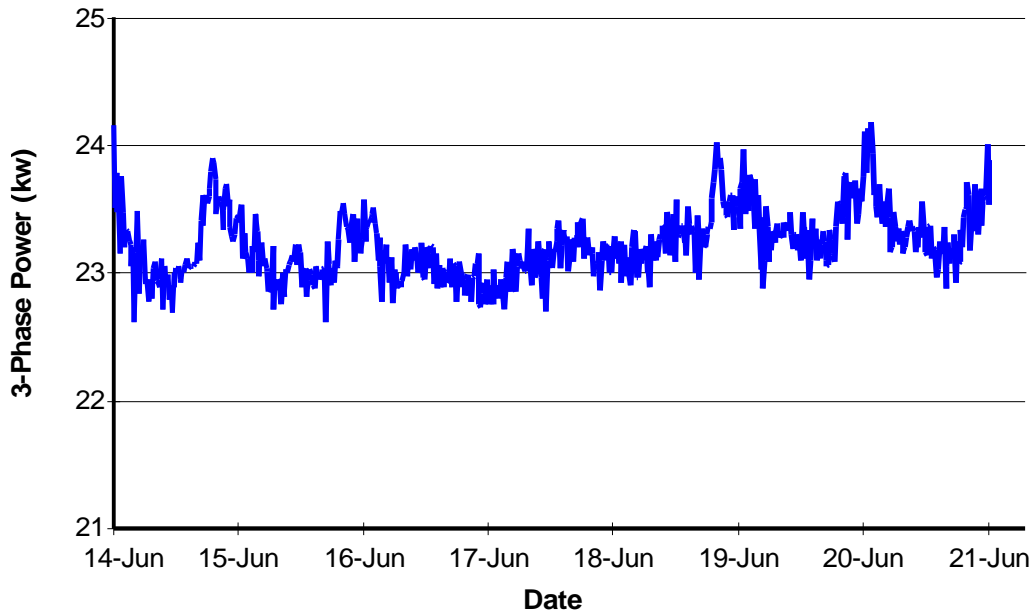

Table 1 provides a sample economic evaluation for an ASD installation for a continuously operating HVAC system motor. This evaluation was for a hospital application in which higher initial ASD costs were expected in order to address harmonic distortion concerns as part of the design. Even so, a payback period of less than 2 years was estimated. As can be seen in Table 1, an ASD economic evaluation is most sensitive to the following assumptions:

- Total motor operating time per year—unless it is fully loaded, a continuously energized motor will show a faster payback than an intermittently energized motor.
- Estimated actual motor load/speed—for a typical centrifugal fan motor, energy usage is proportional to the (speed)<sup>3</sup>. For example, if the motor speed can be reduced to 90 percent of rated speed, the energy usage can be reduced to almost 70 percent of its nominal value.
- Cost per kilowatt hour—the local average energy cost should be used.
- ASD equipment and installation cost—for critical locations, the added cost of ensuring acceptable power quality can double the total initial cost.

**Table 1 Example Adjustable Speed Drive Energy Savings Worksheet**

Input Data for Existing Application

Motor ID #	HVAC Fan - 1	Comments
Motor Horsepower/Watts	60/44,760	Larger motors provide greater payback.
Motor Efficiency (From Nameplate)	91.7%	Evaluate efficiency at less than full load.
Motor Load Factor	50.0%	Existing energy usage is lower if the motor is operating at less than full load. This value is obtained from metering or monitoring.
Number Hours Operation per Year	8,760	Hours of operation per year is particularly important to energy analysis.
Existing Motor Energy Use (kWh/yr)	213,794	$= [(60 \times 0.746)/0.917] \times 8760 \times 0.5$

Calculation for Adjustable Speed Operation

ASD Efficiency	95.0%	Percent	Energy	
Operating Schedule With ASD	Frequency	Speed	Percent Time	(kWh)
$32,812 = [213,794 \times (0.9)^3 \times 0.2]/.95$	54	90.0%	20.0%	32,812
$40,328 = [213,794 \times (0.8)^3 \times 0.35]/.95$	48	80.0%	35.0%	40,328
$27,017 = [213,794 \times (0.7)^3 \times 0.35]/.95$	42	70.0%	35.0%	27,017
$4,861 = [213,794 \times (0.6)^3 \times 0.1]/.95$	36	60.0%	10.0%	4,861
Estimated Energy Use With ASD		Total:		105,018

Economic Analysis and Payback Calculation

Annual Energy Savings (kWh):	108,776	$= (213,794 - 105,018)$
Cost per Kilowatt Hour:	\$0.06	Based on local commercial power rates.
Annual Cost Savings:	\$6,527	$= (108,776 \times \$0.06)$
Estimated Installation Cost Per Motor Horsepower:	\$225	Estimate based on ASD operating requirements and features.
Estimated Installation Cost:	\$13,500	$= (60 \text{ hp} \times \$225)$
Payback Period (Years)	2.07	$= (13,500/6,527)$

Payback periods greater than 5 years should not be approved solely on the basis of economic savings; operating system improvements should also be an identified need for these cases.

**SURGE VOLTAGE LET-THROUGH BY EXCESSIVE LEAD LENGTH.**

Lead length refers to the length of conductor between the circuit connection and a surge protector, and is the critical installation attribute for parallel-type surge protectors. For typical installations, the lead conductor has negligible resistance, but a significant inductance when subjected to a high frequency surge transient. This inductance can develop a substantial voltage drop under surge conditions, thereby proportionately increasing the let-through voltage. Figure 6 shows the

circuit model for this configuration. Each parallel lead develops a voltage drop in addition to the voltage drop across the surge protector. The total let-through voltage is the sum of the three voltage drops.

**Figure 6 Lead Length Effect on Let-Through Voltage**

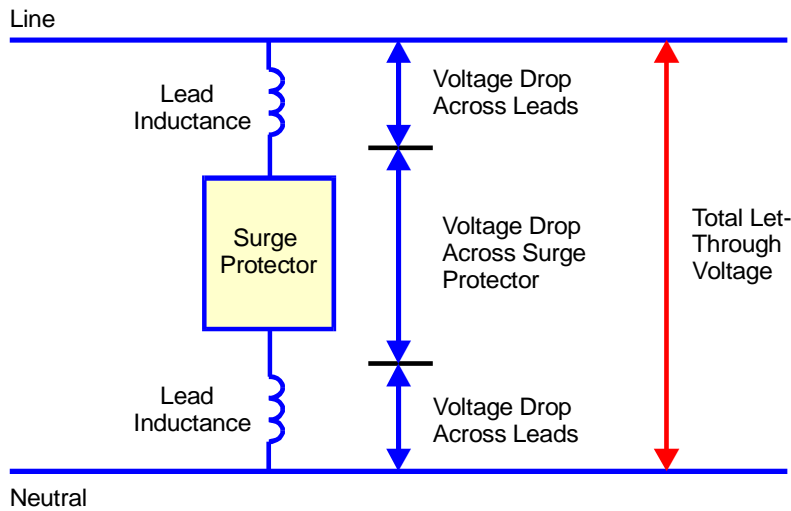

As the lead length is increased, the added inductance increases the voltage drop in proportion to the lead length, with the result that the let-through voltage increases. For example, a surge protector connected by 305 millimeters (12-inch) leads might allow an additional 200 volts of let-through voltage compared to an equivalent surge protector with 152 millimeters (6-inch) leads. The equation for voltage drop as a function of surge current is given by:

$$V = L \frac{di}{dt} + iR$$

EXAMPLE: At the typical surge current frequency, the inductance per foot is near  $0.25 \times 10^{-6}$  henries. The surge current usually has a rise time of  $8 \times 10^{-6}$  seconds. In the above equation, the voltage generated by  $iR$  is negligible compared to the voltage drop across the inductance. Assuming a surge current of 4,000 amperes, the lead length voltage drop per foot is estimated by:

$$V = (0.25 \times 10^{-6}) \frac{4,000}{8 \times 10^{-6}} = 125 \text{ volts per foot}$$

Notice that the voltage drop becomes linearly larger for larger surge currents. The inductance per foot varies with wire gauge size, but this variation is not significant compared to the increase in inductance with length.

**AUTOMATIC TRANSFER SWITCH SIZING.**

The following example illustrates the sizing process for an ATS that is UL listed for *Total System Load* capability.

EXAMPLE: Determine the required size for an ATS rated for *Total System Loads*, for a 208Y/120 volt, three-phase circuit consisting of the following three-phase balanced loads:

1. Resistive heating load: 100 kW or  $I = \frac{100 \text{ kW}}{\sqrt{3} \times 208 \text{ V}} = 278 \text{ amperes}$
2. Incandescent lighting load: 50 kW or  $I = \frac{50 \text{ kW}}{\sqrt{3} \times 208 \text{ V}} = 139 \text{ amperes}$
3. Motors (4) at 32 amperes each, or 128 amperes continuous load, and each motor has approximately 192 amperes inrush on starting.

The total continuous load requirement is 545 amperes. The incandescent lighting load does not exceed 30 percent of the total load. Select an ATS rated for 600 amperes (the next standard ATS size above 545 amperes). Verify with the manufacturer that the ATS is acceptable for the expected motor inrush currents (although it should be fully capable of this inrush per UL 1008).